

# TOOL HOLDER BUSHINGS

D

## TYPE C BUSHINGS

Designed for universal use on all CNC turning machines. To adapt a wide variety of boring bars, drills, reamers and shank type tools. Precision machine hardened and ground concentric.

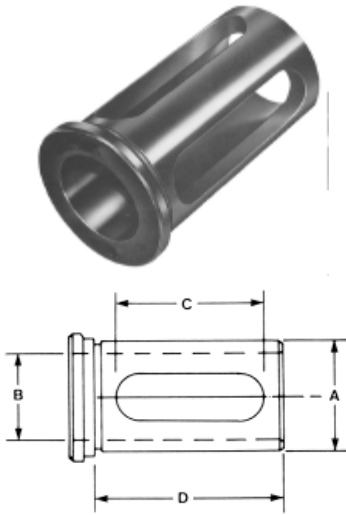

A O.D.	C Slot Length	D Length Under Head	B I.D.	Part Number	Price Each
3/4"	1-7/8"	2-1/4"	1/4"	TBC-07-0250	<b>\$42.75</b>
			5/16"	TBC-07-0312	
			3/8"	TBC-07-0375	
			1/2"	TBC-07-0500	
1"	2-3/8"	2-3/4"	1/4"	TBC-10-0250	<b>\$44.46</b>
			5/16"	TBC-10-0312	
			3/8"	TBC-10-0375	
			1/2"	TBC-10-0500	
			5/8"	TBC-10-0625	
1-1/4"	2-7/8"	3-1/4"	3/4"	TBC-10-0750	<b>\$48.74</b>
			3/8"	TBC-12-0375	
			1/2"	TBC-12-0500	
			5/8"	TBC-12-0625	
			7/8"	TBC-12-0875	
1-1/2"	3"	3-3/8"	1"	TBC-12-1000	<b>\$53.01</b>
			3/8"	TBC-15-0375	
			1/2"	TBC-15-0500	
			5/8"	TBC-15-0625	
			7/8"	TBC-15-0875	
1-3/4"	3-1/8"	3-1/2"	1 1/4"	TBC-15-1000	<b>\$58.14</b>
			1/2"	TBC-15-1250	
			5/8"	TBC-17-0500	
			3/4"	TBC-17-0750	
			7/8"	TBC-17-0875	
2"	3-5/8"	4"	1"	TBC-17-1000	<b>\$61.56</b>
			1 1/4"	TBC-17-1250	
			1-1/2"	TBC-17-1500	
			1/2"	TBC-20-0500	
			5/8"	TBC-20-0625	
			3/4"	TBC-20-0750	<b>\$61.56</b>
			1"	TBC-20-1000	
			1-1/4"	TBC-20-1250	
			1-1/2"	TBC-20-1500	
			1-3/4"	TBC-20-1750	

## TYPE Z BUSHINGS

The most flexible toolholder bushing for all types of N/C-CNC turning centers, turret lathes and chucks. The elongated slots give the user a complete interchangeability with all brands of equipment. Bushings are hardened and precision ground concentric.

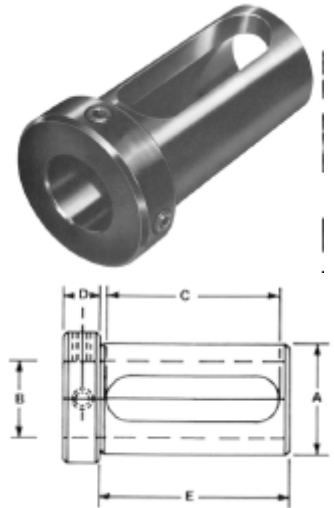

A O.D.	E Length Under Head	D Head Thickness	C Slot Length	B I.D.	Part Number	Price Each
1"	2-3/4"	1/2"	2-3/8"	1/4"	TBZ-10-0250	<b>\$78.66</b>
				5/16"	TBZ-10-0312	
				3/8"	TBZ-10-0375	
				1/2"	TBZ-10-0500	
				5/8"	TBZ-10-0625	
1-1/4"	3"	5/8"	2-5/8"	3/4"	TBZ-10-0750	<b>\$83.79</b>
				3/8"	TBZ-12-0375	
				1/2"	TBZ-12-0500	
				5/8"	TBZ-12-0625	
				7/8"	TBZ-12-0875	
1-1/2"	3-1/4"	3/4"	2-7/8"	1"	TBZ-12-1000	<b>\$83.79</b>
				3/8"	TBZ-15-0375	
				1/2"	TBZ-15-0500	
				5/8"	TBZ-15-0625	
				7/8"	TBZ-15-0875	
1-3/4"	3-1/2"	3/4"	3-1/8"	1"	TBZ-15-1000	<b>\$93.20</b>
				1 1/4"	TBZ-15-1250	
				3/4"	TBZ-17-0500	
				5/8"	TBZ-17-0625	
				7/8"	TBZ-17-0875	
2"	3-3/4"	3/4"	3-3/8"	1"	TBZ-17-1000	<b>\$104.31</b>
				1 1/4"	TBZ-17-1250	
				1-1/2"	TBZ-17-1500	
				1/2"	TBZ-20-0500	
				5/8"	TBZ-20-0625	
				3/4"	TBZ-20-0750	<b>\$104.31</b>
				7/8"	TBZ-20-0875	
				1"	TBZ-20-1000	
				1-1/4"	TBZ-20-1250	
				1-1/2"	TBZ-20-1500	
				1-3/4"	TBZ-20-1750	<b>\$104.31</b>

**QUANTITY DISCOUNTS  
ON TOOLHOLDER BUSHINGS!**  
Buy 5 or More Bushings & Save 5%!  
(You Can Mix & Match Sizes and Styles)

Call Us Today For All Of Your Machine Tool Needs!

# TOOL HOLDER BUSHINGS

D

## TYPE J BUSHINGS

Type J bushings have clearance holes so that you can clamp directly on the tool with set screws for positive alignment of the cutting edge of the tool.

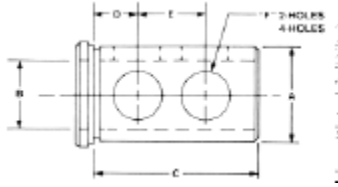

**QUANTITY DISCOUNTS  
ON TOOLHOLDER BUSHINGS!**  
Buy 5 or More Bushings & Save 5%!  
(You Can Mix & Match Sizes and Styles)

A O.D.	C	E	D	F	B I.D.	Part Number	Price Each
3/4"	1-1/2"	13/16"	3/8"	3/8"	1/4"	TBJ-07-0250	<b>\$32.49</b>
					5/16"	TBJ-07-0312	
					3/8"	TBJ-07-0375	
1/2"	TBJ-07-0500						
3/8"	TBJ-10-0375						
1"	1-3/4"	7/8"	7/16"	5/8"	1/2"	TBJ-10-0500	<b>\$35.91</b>
					5/8"	TBJ-10-0625	
					3/4"	TBJ-10-0750	
3/8"	TBJ-12-0375						
1/2"	TBJ-12-0500						
1-1/4"	2-1/8"	1"	5/8"	5/8"	3/4"	TBJ-12-0750	<b>\$39.33</b>
					7/8"	TBJ-12-0875	
					1"	TBJ-12-1000	

A O.D.	C	E	D	F	B I.D.	Part Number	Price Each
1-1/2"	2-1/2"	1-1/8"	11/16"	7/8"	3/8"	TBJ-15-0375	<b>\$42.75</b>
					1/2"	TBJ-15-0500	
					5/8"	TBJ-15-0625	
					3/4"	TBJ-15-0750	
					7/8"	TBJ-15-0875	
1"	TBJ-15-1000						
1-3/4"	3"	1-1/4"	3/4"	7/8"	1-1/4"	TBJ-15-1250	<b>\$51.30</b>
					1/2"	TBJ-17-0500	
					5/8"	TBJ-17-0625	
					3/4"	TBJ-17-0750	
					7/8"	TBJ-17-0875	
1"	TBJ-17-1000						
1-1/4"	TBJ-17-1250						
2"	3-1/2"	1-1/2"	3/4"	1	1-1/2"	TBJ-17-1500	<b>\$54.72</b>
					1/2"	TBJ-20-0500	
					5/8"	TBJ-20-0625	
					3/4"	TBJ-20-0750	
					7/8"	TBJ-20-0875	
1"	TBJ-20-1000						
1-1/4"	TBJ-20-1250						
1-1/2"	TBJ-20-1500						
1-3/4"	TBJ-20-1750						

## TYPE DD BUSHINGS

Combination of the industry standard "B" style split bushing and "J" set screw clearance bushing design. This bushing with clearance holes and split milled flat can be used as a conventional "B" style or "J" style bushing.

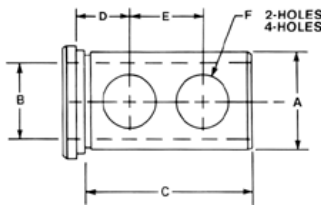

A Outside Dia	C Length Under Head	D	E	F Hole Size	No. of Holes	B Inside Dia.	Part Number	Price Each
1 1/2	2 1/2	11/16	1 1/8	7/8	2	3/8	TBDD-15-0375	<b>\$60.80</b>
						1/2	TBDD-15-0500	
						5/8	TBDD-15-0625	
						3/4	TBDD-15-0750	
						7/8	TBDD-15-0875	
						1	TBDD-15-1000	
1 1/4	TBDD-15-1250							
1 3/4	3	3/4	1 1/4	7/8	2	1/2	TBDD-17-0500	<b>\$66.50</b>
						5/8	TBDD-17-0625	
						3/4	TBDD-17-0750	
						7/8	TBDD-17-0875	
						1	TBDD-17-1000	
						1 1/4	TBDD-17-1250	
1 1/2	TBDD-17-1500							
2	3 1/2	3/4	1 1/2	1	2	1/2	TBDD-20-0500	<b>\$74.10</b>
						5/8	TBDD-20-0625	
						3/4	TBDD-20-0750	
						7/8	TBDD-20-0875	
						1	TBDD-20-1000	
						1 1/4	TBDD-20-1250	
1 1/2	TBDD-20-1500							
1 3/4	TBDD-20-1750							
2 1/2	4	7/8	1 3/4	1 1/4	2	1/2	TBDD-25-0500	<b>\$87.40</b>
						5/8	TBDD-25-0625	
						3/4	TBDD-25-0750	
						7/8	TBDD-25-0875	
						1	TBDD-25-1000	
						1 1/4	TBDD-25-1250	
1 1/2	TBDD-25-1500							
1 3/4	TBDD-25-1750							
2	TBDD-25-2000							
2 1/4	TBDD-25-2250							
3	4 1/2	1	2	1 1/4	4	1	TBDD-30-1000	<b>\$106.40</b>
						1 1/4	TBDD-30-1250	
						1 1/2	TBDD-30-1500	
						1 3/4	TBDD-30-1750	
						2	TBDD-30-2000	
						2 1/4	TBDD-30-2250	
2 1/2	TBDD-30-2500							
3 1/2	5 1/4	1 1/4	2 1/2	1 1/4	4	1 1/2	TBDD-35-1500	<b>\$134.90</b>
						1 3/4	TBDD-35-1750	
						2	TBDD-35-2000	
						2 1/4	TBDD-35-2250	
						2 1/2	TBDD-35-2500	
						3	TBDD-35-3000	

**ALSO AVAILABLE!**  
Type SL-35 (for Moriseiki SL-35)  
Please Call For More Information!



Type SL-35

Call Us Or Visit Our Website For Our Complete Selection!

# TOOL HOLDER BUSHINGS

D

## TYPE LB BUSHINGS

This long solid body bushing has four clearance holes so that you can clamp directly on the tool with set screws for positive alignment of the cutting edge of the tool. Manufactured to include clearance notches for coolant. Hardened and precision ground concentric.

**FOR OKUMA  
LB-15 LATHES**

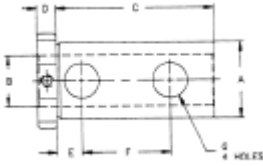

A O.D.	C	D	E	F	B I.D.	Part Number	Price Each
1-1/2"	3-1/8"	3/8"	1/2"	1-3/4"	1/4"	TBLB-15-0250	<b>\$83.79</b>
					3/8"	TBLB-15-0375	
					1/2"	TBLB-15-0500	
					5/8"	TBLB-15-0625	
					3/4"	TBLB-15-0750	
					7/8"	TBLB-15-0875	
					1"	TBLB-15-1000	
					1-1/4"	TBLB-15-1250	

## TYPE LBF BUSHINGS

Manufactured with a flat for clamping the toolholder and two set screws for clamping a variety of drill, boring bars and other shank tools. Equipped with two clearance notches for coolant. Heat treated and precision ground concentric.

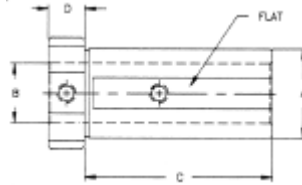

A OD	C	D	B ID	Part Number	Price Each
1-1/2"	3-5/32"	5/8"	1/4"	TBLBF-15-0250	<b>\$83.79</b>
			3/8"	TBLBF-15-0375	
			1/2"	TBLBF-15-0500	
			5/8"	TBLBF-15-0625	
			3/4"	TBLBF-15-0750	
			7/8"	TBLBF-15-0875	
			1"	TBLBF-15-1000	
			1-1/4"	TBLBF-15-1250	

## TYPE B BUSHINGS

These split bushings are made with flexible manufacturing systems for all types and sizes of NC and CNC lathes and chuckers. Used to adapt drills, boring bars and other shank tools, these bushings are heat treated and precision ground concentric.

**QUANTITY DISCOUNTS  
ON TOOLHOLDER BUSHINGS!  
Buy 5 or More Bushings & Save 5%!  
(You Can Mix & Match Sizes and Styles)**

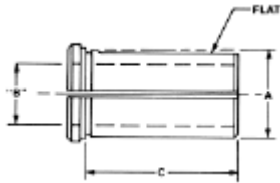

A OD	C	B ID	Part Number	Price Each	A OD	C	B ID	Part Number	Price Each			
3/4	1 1/2	1/4	TBB-07-0250	<b>\$38.00</b>	1 1/2	2 1/2	3/8	TBB-15-0375	<b>\$49.40</b>			
		5/16	TBB-07-0312									
		3/8	TBB-07-0375									
1/2	TBB-07-0500											
1	1 3/4	3/8	TBB-10-0375	<b>\$41.80</b>			1 3/4	3		5/8	TBB-17-0625	<b>\$58.90</b>
		1/2	TBB-10-0500									
		5/8	TBB-10-0625									
		3/4	TBB-10-0750									
1 1/4	2 1/8	3/8	TBB-12-0375	<b>\$45.60</b>	1 3/4	3	1/2	TBB-17-0500	<b>\$58.90</b>			
		1/2	TBB-12-0500									
		5/8	TBB-12-0625									
		3/4	TBB-12-0750									
		7/8	TBB-12-0875									
		1	TBB-12-1000									

Larger Sizes Also Available, Please Call For More Information

## TYPE L BUSHINGS

"L" style bushings are used to adapt drill, boring bars and shank tools to any size in a standard turret or toolholder. All "L" style bushings have set screw clearance holes opposite the slot and have a split with a flat on the O.D.

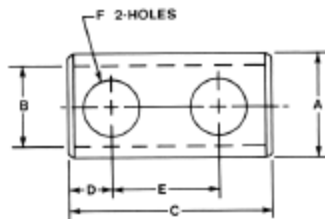

A O D	C OAL	D	E	F	No Of Holes	B I D	Part Number	Price Each
1 1/2	3	3/4	1 5/8	7/8	2	3/8	TBL-15-0375	<b>\$61.75</b>
						1/2	TBL-15-0500	
						5/8	TBL-15-0625	
						3/4	TBL-15-0750	
						1	TBL-15-1000	
						1 1/4	TBL-15-1250	

A O D	C OAL	D	E	F	No Of Holes	B I D	Part Number	Price Each
1 3/4	3	3/4	1 5/8	7/8	2	1/2	TBL-17-0500	<b>\$68.40</b>
						5/8	TBL-17-0625	
						3/4	TBL-17-0750	
						1	TBL-17-1000	
						1 1/4	TBL-17-1250	
						1 1/2	TBL-17-1500	
2 1/4	4 1/2	7/8	2	1	2	5/8	TBL-22-0625	<b>\$76.00</b>
						3/4	TBL-22-0750	
						1	TBL-22-1000	
						1 1/4	TBL-22-1250	
						1 1/2	TBL-22-1500	
						1 3/4	TBL-22-1750	
2 3/4	4 1/2	7/8	2	1	2	2	TBL-22-2000	<b>\$91.20</b>
						3/4	TBL-27-0750	
						1	TBL-27-1000	
						1 1/4	TBL-27-1250	
						1 1/2	TBL-27-1500	
						1 3/4	TBL-27-1750	
2	TBL-27-2000							
2 1/4	TBL-27-2250							

**Call Us Today For All Of Your Machine Tool Needs!**

# TOOL HOLDER BUSHINGS

D

## BORING BAR SLEEVES

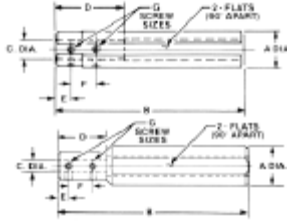

Boring bar sleeves are used to adapt all boring bar or shank type tools to any CNC turning machine or machining center for extensions or hard to reach areas. They are hardened, precision ground concentric and black oxidized for long life. Innovative design on the 1-1/2 OD boring bar sleeves helps the tools stay cool longer by projecting the coolant directly on the cutting edge.

A	B	Scw Size	E	F	D	C	Part Number	Price Each
3/4	5	10-32	5/16	5/8	1 1/2	1/4	TBBS-07-0250	\$71.25
						5/16	TBBS-07-0312	
						3/8	TBBS-07-0375	
						3	TBBS-07-0500	
1	6	1/4-28	7/16	5/8	1 3/4	5/16	TBBS-10-0312	\$71.25
						3/8	TBBS-10-0375	
						2	TBBS-10-0500	
						2	TBBS-10-0500	
1 1/4	6 1/2	1/4-28	7/16	5/8	1 1/2	3/8	TBBS-12-0375	\$86.45
						1/2	TBBS-12-0500	
						5/8	TBBS-12-0625	
		10-32	3/4	3	3/4	TBBS-12-0750		
					7/8	TBBS-12-0875		
					4	TBBS-12-1000		
1 1/2	7	1/4-28	5/16	5/8	2	3/8	TBBS-15-0375	\$89.30
						11/16	TBBS-15-0500	
						2 1/4	TBBS-15-0625	
		7/16	3/4	2 1/2	3/4	TBBS-15-0750		
					3	TBBS-15-0875		
					7/8	TBBS-15-1000		

A	B	Scw Size	E	F	D	C	Part Number	Price Each
1 3/4	8	5/16-24	5/16	5/8	2 1/2	1/2	TBBS-17-0500	\$97.85
		5/16-24	7/16	1	2 1/2	5/8	TBBS-17-0625	
		3/8-24	7/16	1	2 1/2	3/4	TBBS-17-0750	
						7/8	TBBS-17-0875	
2	9	7/16-20	7/16	1	2	5/8	TBBS-20-0625	\$109.25
						3/4	TBBS-20-0750	
						2	TBBS-20-0875	
						3 1/2	TBBS-20-1000	
						5/8	TBBS-20-1250	
2 1/2	10	1/2-20	7/16	1	3 1/2	5/8	TBBS-25-0625	\$128.25
						3/4	TBBS-25-0750	
						1	TBBS-25-1000	
						1 1/4	TBBS-25-1250	
						1/2	TBBS-25-1500	
3	11-1/2	1/2-20	1/2	1	4	1	TBBS-30-1000	\$166.25
						1 1/4	TBBS-30-1250	
						1 1/2	TBBS-30-1500	
						3 1/2	TBBS-30-1750	
						4 1/2	TBBS-30-2000	
						5/8	TBBS-30-2500	
4	14	5/8-18	1/2	1 1/8	3 3/4	1 1/2	TBBS-40-1500	\$289.75
						1 3/4	TBBS-40-1750	
						2	TBBS-40-2000	
						2 1/2	TBBS-40-2500	
						3/4	TBBS-40-3000	
						1 1/4	TBBS-40-3000	

## BORING BAR SLEEVES-SHORT LENGTH



Heat treated and precision ground. Two lockdowns at 90° for secure fastening. Max T.I.R. .002"

Excellent for Solid Carbide:

- Boring Tools
- Grooving Tools
- Threading Tools

**MICRO 100**

C

**Full Line Available!**  
Please call for more information.

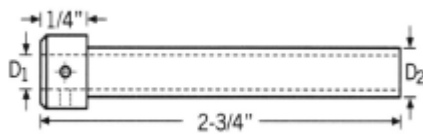

OD	OAL	Head Thickness	ID	Part Number	Price Each
1/2"	2-3/4"	1/4"	1/8	MI-TH84	\$19.25
			3/16	MI-TH85	
			1/4	MI-TH86	
			5/16	MI-TH87	
			3/8	MI-TH88	
5/8"	2-3/4"	1/4"	1/8	MI-TH104	\$19.25
			3/16	MI-TH105	
			1/4	MI-TH106	
			5/16	MI-TH107	
			3/8	MI-TH108	
3/4"	2-3/4"	1/4"	1/8	MI-TH204	\$23.90
			3/16	MI-TH205	
			1/4	MI-TH206	
			5/16	MI-TH207	
			3/8	MI-TH208	

## TYPE G BUSHINGS For Gang Tools



- 3/4" Long head helps equalize the tool length compared to collet chuck and OD tool holders.
- Set screw helps preset the tools flat on the bushing for ease of clamping
- Ground concentric

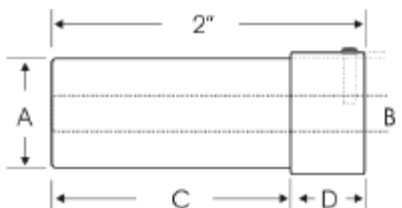

A OD	C Length Under Head	D Head Thickness	Clearance Groove	Head Dia. Nominal	B ID	Part Number	Price Each
<b>Part Stop/ Plug</b>							
3/4	1-1/4	3/4	0.04	7/8	-	TBG-07-0125	\$29.95
<b>Bushings</b>							
3/4	1-1/4	3/4	0.04	7/8	1/8	TBG-07-0125	\$34.95
					3/16	TBG-07-0187	\$29.95
					1/4	TBG-07-0250	\$29.95
					5/16	TBG-07-0312	\$29.95
					3/8	TBG-07-0375	\$29.95
					1/2	TBG-07-0500	\$29.95

Buy All 7 And Save 10% From Individual Prices

**Call Us Or Visit Our Website For Our Complete Selection!**