

ROUND JAWS- Acme Serrated Key Type

For Use On: Cushman, Logansport, Howa, Autoblok, PBA & Other Chucks

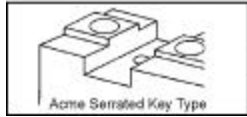

Group

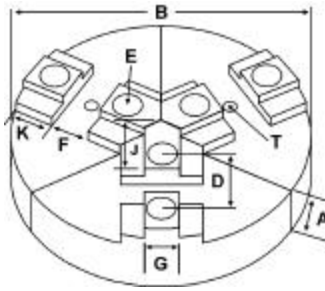

- Round Jaws allow for complete gripping of workpiece.
- Oversized jaws available.
- Ideal for thin-walled or irregular shaped workpieces.
- Can be machined to fit workpiece.
- Available in Aluminum, Cast Iron & Steel.
- Made in the USA.



Group No.	Chuck Size	Tap Hole T	Key to Front J	Critical Dimensions				Pie Dia B	Hght Inch A	ALUMINUM		CAST IRON	
				Groove Width G	Key Width F	Screw Size E	Hole Space D			Part Number	Price Set Of 3	Part Number	Price Set Of 3
AI-06-1/2-12	8	10-24	2.000	0.670	0.601	1/2	1.25	8	2.00	RAC-8200A	103.98	RAC-8200CI	115.20
									4.00	RAC-8400A	145.57	RAC-8400CI	217.59
AI-07-1/2-17	10	5/16-18	2.750	0.750	1.031	1/2	1.75	10	2.00	RAC-10200A	136.45	RAC-10200CI	172.80
									4.00	RAC-10400A	210.47	RAC-10400CI	307.19
									12	2.00	12-RAC-10200A	177.32	-
AI-08-5/8-20	12	5/16-18	3.250	0.875	1.031	5/8	2.00	12	2.00	RAC-12200A	177.32	RAC-12200CI	255.99
									4.00	RAC-12400A	351.92	-	-
									15	4.00	15-RAC-10400A*	481.98	-
AI-10-3/4-25	15	3/8-16	4.250	1.000	1.531	3/4	2.50	15	2.50	RAC-15250A	392.31	RAC-15250CI	477.98
									4.00	RAC-15400A	481.98	-	-
									5.00	RAC-15500A	753.41	-	-
									18	4.00	18-RAC-15400A*	674.80	-
AI-12-7/8-30	21 - 24	3/8-16	4.550	1.250	1.531	7/8	3.00	18	4.00	18-RAC-21400A	674.80	-	-
			6.650						21	4.00	RAC-21400A	899.87	-

Round Jaw Material: ALUMINUM-6061-T6 Bar Stock, CAST IRON-Gray, STEEL-1018, 18" & Larger- Aluminum Casting T6

For complete list of applicable chucks, see pages 54-66.

* denotes non-stock item. Please allow 1 week manufacturing time.

HARD JAWS

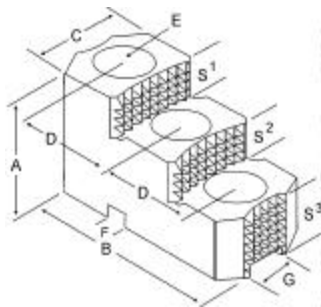

- Designed for first operation roughing, standard runout between 0.005-0.010
- 1 & 2 step jaws available.
- Reversible-suitable for OD & ID workholding.
- OEM Style have ground tips and provide improved runout.
- Extra Bite have conical teeth for extra gripping power and black oxide for long life. Made in the USA.



Group No.	Chuck Size	Critical Dimensions						Hght Inch A	No. of Steps	Step Height S1	Step Height S2	Step Height S3	Part Number	Price Set Of 3
		Groove Width G	Key Width F	Screw Size E	Hole Space D	Width Inch C	Length Inch B							
AI-07-1/2-17	10	0.750	1.031	1/2	1.750	1.750	4.150	2.500	2	0.620	0.630	1.250	AC-100HJ2	514.50
AI-08-5/8-20	12	0.875	1.031	5/8	2.000	1.750	5.210	2.500	2	0.510	0.860	1.130	AC-120HJ2	661.50
AI-10-3/4-25	15 - 18	1.000	1.531	3/4	2.500	2.500	6.030	3.500	2	0.810	1.090	1.600	AC-150HJ2	779.10

Call Us Today For All Of Your Machine Tool Needs!

SOFT JAWS- Acme Serrated Key Type

C

For Use On: Cushman, Logansport, Howa, Autoblok, PBA & Other Chucks

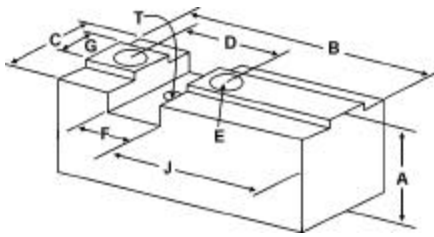

- Supplies maximum concentricity on finish turning operations.
- Can be bored or turned to fit workpiece.
- Steel jaws can be hardened.
- Available pointed for smaller diameter parts.
- Special orders available
- Available in Aluminum, Steel & Aircraft Aluminum.

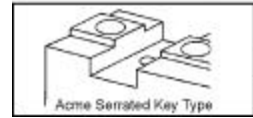

Group
AI

QUANTITY DISCOUNTS!
Order **5 SETS OR MORE** of the same part number soft jaws and receive a **5% DISCOUNT!**



Group No.	Chuck Size	Tap Hole T	Key to Front J	Critical Dimensions				Width Inch C	Length Inch B	Hght Inch A	ALUMINUM		STEEL	
				Groove Width G	Key Width F	Screw Size E	Hole Space D				FLAT END Part Number	Price Set Of 3	FLAT END Part Number	Price Set Of 3
AI-06-1/2-12	8	10-24	2.000	0.670	0.601	1/2	1.250	1.50	3.75	2.00	AC-8200AF	57.20	AC-8200F	61.24
	9	10-24	2.000	0.670	0.601	1/2	1.250	1.50	3.75	4.00	AC-8400AF	80.63	AC-8400F	87.48
AI-07-1/2-17	10	5/16-18	2.250	0.750	1.031	1/2	1.750	1.75	4.25	2.50	AC-10250AF	64.75	AC-10250F	68.90
3.425			0.750	1.031	1/2	1.750	1.75	5.50	4.00	AC-10400AF	86.64	AC-10400F	91.85	
			2.50	0.875	1.031	5/8	2.000	1.75	5.25	2.50	AC-10251AF*	70.56	AC-10251F*	76.56
			3.000	0.875	1.031	5/8	2.000	1.75	5.25	4.00	AC-10401AF*	91.59	AC-10401F*	99.36
AI-08-5/8-20	12	5/16-18	3.125	0.875	1.031	5/8	2.000	1.75	5.25	2.50	AC-12250AF	72.08	AC-12250F	76.56
3.00										AC-12300AF	95.21	AC-12300F	101.30	
4.00										AC-12400AF	94.16	AC-12400F	99.51	
AI-10-3/4-25	15 - 18	3/8-16	3.000	1.000	1.531	3/4	2.500	2.00	6.25	2.50	AC-12500AF	143.91	AC-12500F	152.82
4.00										AC-15250AF	86.74	AC-15250F	91.85	
4.00										AC-15400AF	109.16	AC-15400F	114.82	
2.50										AC-18250AF	108.54	AC-18250F	114.82	
AI-12-7/8-30	21 - 24	3/8-16	2.625	1.250	1.531	7/8	3.000	2.50	6.25	4.00	AC-18400AF	131.85	AC-18400F	129.54
5.00										AC-18500AF	167.98	AC-18500F	182.24	
4.00										AC-21400AF	131.85	AC-21400F	138.37	
										5.00	AC-21500AF	181.57	AC-21500F	191.36

For "Pointed" Soft Jaws, please substitute "P" for "F" in the part number. Example: AC-8200AF will be AC-8200AP. Pointed Jaws: Up to 10" add \$3.25, 12" & over add \$6.50.
Soft Jaw Material: ALUMINUM-6061-T6 Bar Stock, STEEL-1018, "B" JAWS-7075-T6 Aircraft Aluminum
For complete list of applicable chucks, see pages 54-66. * denotes non-stock item. Please allow 1 week manufacturing time.

JAW NUTS & MASTER KEYS

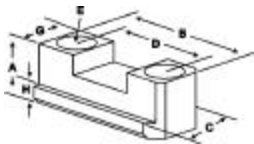

Chuck Size	Critical Dimensions					2 Screws Included With Each Jaw Nut					
	Heel Height H	Groove Width G	Screw Size E	Holes Space D	Hght Inch A	Width Inch C	Length Inch B	Jaw Nut Part Number	Price Each	Screw Part Number	Price Each
8	0.440	0.667	1/2-13	1.250	1.000	1.030	2.00	AC-80JN	48.88	S1/213150	1.50
10	0.380	0.677	1/2-13	1.750	0.641	0.940	2.50	AC-100JN	44.33	S1/213150	1.50
12	0.440	0.801	5/8-11	2.000	0.744	1.060	3.00	AC-125JN	46.37	S5/811150	2.50
15 - 18	0.550	0.933	3/4-10	2.500	0.930	1.250	3.50	AC-155JN	48.88	S3/410175	3.50
21 - 24	0.684	1.158	7/8-9	3.000	1.185	1.554	4.25	AC-215JN	61.09	S7/809175	5.00

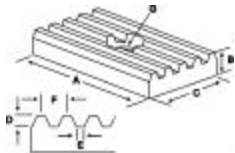

Chuck Size	Critical Dimensions				Width Inch C	Height Inch B	Length Inch A	Master Key Part Number	Price Each
	Screw Size G	Pitch F	Slot E	Depth D					
8	10-24	0.250	0.093	0.130	0.600	3/8"	1.500	AC-80AK	29.26
10-12	5/16	0.250	0.093	0.130	1.030	1/2"	1.687	AC-120AK	31.70
10-12	3/8	0.250	0.093	0.130	1.187	1/2"	2.000	AC-125AK	36.57
15-18	3/8	0.250	0.093	0.130	1.530	1/2"	2.000	AC-150AK	39.01
15-18	3/8	0.250	0.093	0.130	1.530	1/2"	2.437	AC-180AK	39.01
21-24	3/8	0.250	0.093	0.130	1.530	1/2"	2.875	AC-210AK	40.23

Call Us Or Visit Our Website For Our Complete Selection!

2005-06 Product Catalog

41

Soft, Round & Hard Jaws

5C, 16C, CHICK Collet Chucks

Precision ER Collets Coolant & Tapping

Drill Chucks Tapping Equip

Spade Drills HSS/Carbide Inserts

Carbide Tools Micro 100

Knurling Tools Bandsaw Blades

Flat Stock/Drill Rod Tooling Components