

# FACE DRIVERS/COLLET CHUCKS

C

**Complete Turning in One Operation!** Riten Face Drivers, used in conjunction with Riten Live or Dead Centers, allow the complete turning or grinding of the entire outside diameter of a workpiece in a single operation. Even facing or chamfering of the ends of the part can be accomplished with the careful selection of the correct face driver and drive pins. Unlike a chuck or grinding dog, a face driver grips and turns the part by locating only on the face of the workpiece. With a chuck or grinding dog, the part must be removed after the first operation, reversed and rechucked before any more operations can be performed. Traditional machining requires multiple operations and setups that increase costs and cycle times, and reduce part quality.



**Machine The Entire Length Of The Workpiece At High Speeds!**

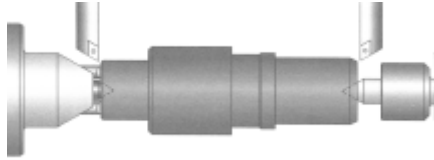

- Advantages Of Using A Face Driver:**
- Penetrate workpieces up to 42 Rc
  - Eliminate outside diameter clamping
  - Greater accuracy and improved part quality
  - Excellent repeatability
  - Faster load times
  - Automatic part loading
  - Eliminate facing of the workpiece
  - Increase production

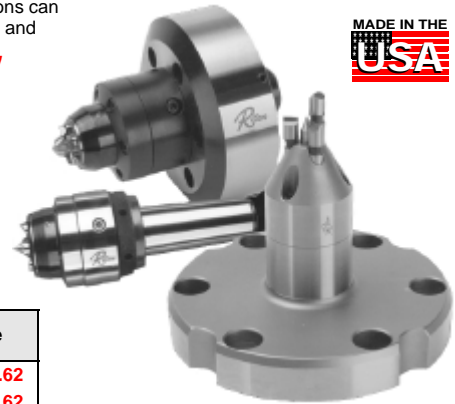

## Mounting Styles:

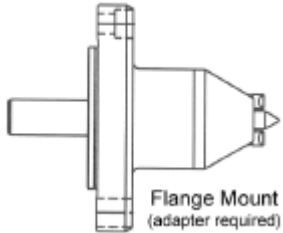
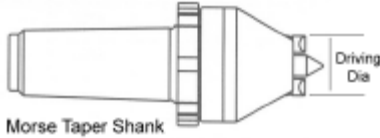

Driving Dia. (inches)	Mounting	Type	Part Number	Price
.51-1.02	4MT	43	RI-4304	\$1,586.62
	5MT	43	RI-4305	\$1,586.62
	Flange*	43	RI-43FM	\$2,243.22
1.02-1.42	4MT	44	RI-4404	\$1,810.06
	5MT	44	RI-4405	\$1,887.48
	Flange*	44	RI-44FM	\$2,669.52
1.34-1.73	4MT	45	RI-4504	\$2,044.28
	5MT	45	RI-4505	\$2,123.66
	Flange*	45	RI-45FM	\$3,005.66
1.54-2.32	4MT	47	RI-4705	\$2,785.16
	5MT	47	RI-4706	\$2,914.52
	Flange*	47	RI-47FM	\$4,202.24

\*Requires A Spindle Nose Adapter

## Spindle Nose Adapters

Spindle Nose	Part Number	Price
A2 - 5"	RI-708037	\$979.02
A2 - 6"	RI-708038	\$1,043.70
A2 - 8"	RI-708039	\$1,108.38

## COLLET CHUCKS For CNC Lathes

These productivity enhancing systems have a built-in concentricity adjustment (under 0.00050" TIR) and can be mounted on all American standard spindles in less than 20 minutes. Only one complete chuck assembly is required because each spindle adapter of the assembly will accept any of Dunham's 5C, 16C, 3J and 2J collet adapters. Change-over is accomplished quickly and easily by the removal and replacement of only six bolts on the collet adapter.

### FEATURES:

- Adapts CNC lathes for standard 5C, 16C, 3J and 2J collets.
- Each spindle mount will accept 5C, 16C, 3J and 2J collet adapter.
- Built in concentricity adjustment.
- Workholders are actuated by machine closer.
- Light weight permits higher turning speeds.
- Balanced design for smooth running.
- Easy installation! Mounts in less than 20 minutes!

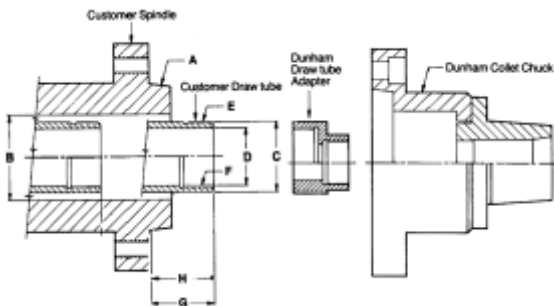
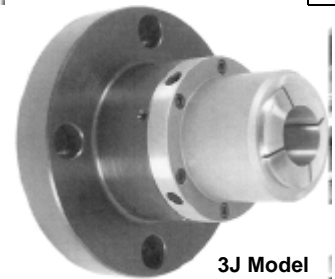
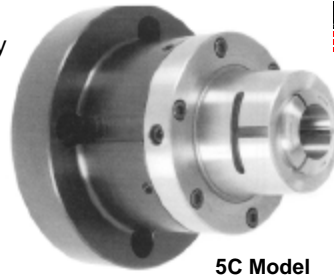

**When placing an order, please provide us with the following information:**  
 Machine make and model number.  
 A. Spindle Size  
 B. spindle I.D.  
 C. O.D. Draw Tube  
 D. I.D. Draw Tube  
 E. Draw tube external thread size  
 F. Draw tube internal thread size  
 G. Draw tube fully extended  
 H. Draw tube fully retracted

Collet Type	Spindle	Cap.	Threaded Nose	Part Number	Price Each
5C	A4	1 1/16	N	DTC-5C-4T-A4	\$564.00
	A5	1 1/16	N	DTC-5C-4T-A5	\$576.00
	A6	1 1/16	N	DTC-5C-4T-A6	\$605.00
	A8	1 1/16	N	DTC-5C-4T-A8	\$719.00
5C	A4	1 1/16	Y	DTC-5CTHD-A4	\$605.00
	A5	1 1/16	Y	DTC-5CTHD-A5	\$616.00
	A6	1 1/16	Y	DTC-5CTHD-A6	\$651.00
	A8	1 1/16	Y	DTC-5CTHD-A8	\$748.00
16C	A4	1 5/8	N/A	DTC-16C-A4	\$702.00
	A5	1 5/8	N/A	DTC-16C-A5	\$742.00
	A6	1 5/8	N/A	DTC-16C-A6	\$742.00
	A8	1 5/8	N/A	DTC-16C-A8	\$781.00
3J	A4	1 3/4	N/A	DTC-3J-A4	\$702.00
	A5	1 3/4	N/A	DTC-3J-A5	\$742.00
	A6	1 3/4	N/A	DTC-3J-A6	\$742.00
	A8	1 3/4	N/A	DTC-3J-A8	\$781.00

Drawnut Not Included. Please Add \$165.00 For Threaded Drawnut

**Call Us Or Visit Our Website For Our Complete Selection!**